

PRODUCT RANGE

59-020-060 Deluxe Stereo Microscope

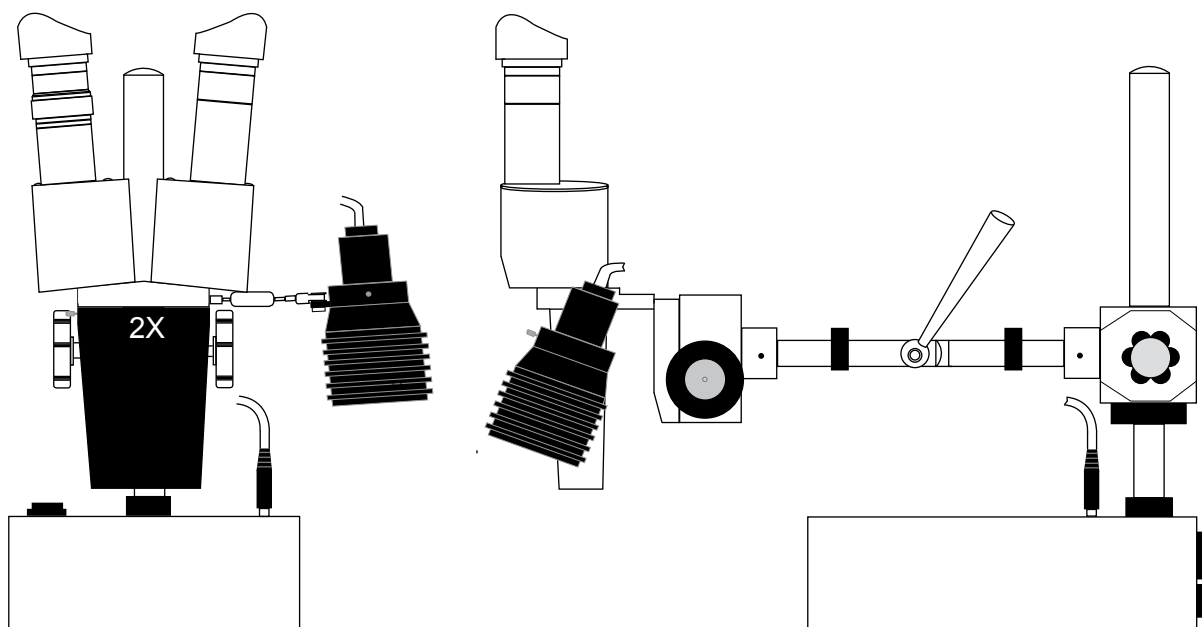

GENERAL DESCRIPTION

This Long Reach Stereo Microscope is suitable for viewing the surface of items which will not fit onto the stage plates of conventional microscopes.

GENERAL SPECIFICATION

- Two 10x magnification Wide Field Eye Pieces.
- Two Rubber Eye Cups for fitting to Eye Pieces.
- Eye Piece width adjustment 50 – 75mm.
- 2x Objective Lens.
- Microscope provides 20x viewing magnification.
- Focal distance between base of Objective Lens and work piece = 115mm.
- Field of view at 20X mag. = 10mm.
- Max. working height between bench top and objective lens = 200mm.
- Rack and pinion adjustment = 45mm.
- On/Off power switch.
- Side mounted articulated illumination lamp 12v 10w Halogen.
- Base dimensions: 195mm long, 120mm wide, 65mm high.
- Upright column: 210mm high x 18mm dia.
- Articulated Cross arm: 270mm total length between upright column and lens.
- Plastic dust cover .
- Primary voltage 230v AC.
- Secondary voltage 12v 10w.

OPERATING INSTRUCTIONS

Carefully unpack the microscope from its fitted shipping box
Remove the protective plastic bag which covers the microscope
Place the microscope onto a solid work bench
Fit the rubber eye cups to the eye pieces
Remove paper covering the magnification and objective lenses
Connect the 3 pin plug to the required electric mains supply
Place the work piece onto the bench top
Position the Microscope head approximately 115mm above the surface of the work piece
Switch on the illumination lamp if required
Look through Eye pieces and adjust lenses to correct eye width distance
Rotate either of the two side adjusting knobs to focus onto the required surface
When in general focus a fine adjustment can be made by adjusting the left hand magnification lens to balance with the right hand lens by rotating the left hand lens mount.

When the final focus has been made, the microscope head can be locked in this position by using the " C " spanner provided, to tighten the locking collar situated on one of the adjusting knob spindles against the microscope body
To replace the magnification lens, partially withdraw the small cross head location screw situated just below the lens, this will allow the lens to be pulled from its location tube. To replace the lens, fit lens into tube until the small cross head screw is in line with the annular groove situated around the lens body, then retighten the screw.

BULBS/ADDITIONAL ACCESSORIES

Microscope is fitted with two 250V T1A Glass fuses

Illumination before Feb. 2000

Illumination lamp: 12v 2w Pea style bulb (Linear code 59-020-101)

Illumination after Feb. 2000

Illumination lamp: 12v 10w Halogen (Linear code 59-020-102)

To change this lamp, unscrew black heatsink tube from front of lamp housing, pull out old lamp and push new one firmly into the 2 pin holes.

Replace the heatsink tube.

Additional accessories:

Eye Piece 15X (Code 59-020-041)

Eye Piece 20X (Code 59-020-042)

Eye Piece 10X with Metric Scale consisting of:

Horizontal Scale 0 – 16mm in 0.1mm graduations

Vertical Scale 0 – 16mm in 0.5mm graduations

Diagonal cross lines giving 30, 60 & 45 deg. angles (Code 59-020-045)

Objective Lens 1X (Code 59-020-105)

MAGNIFICATION DATA

Magnification	Widefield Eyepiece	Product Code	Objective Lens	Product Code	Focal Length	Fields Of View
20x	10x	Fitted	2x	Fitted	115mm	10mm
30x	15x	59-020-041	2x	Fitted	115mm	5mm
40x	20x	59-020-042	2x	Fitted	115mm	2.5mm
10x	10x	Fitted	1x	59-020-049	115mm	20mm
15x	15x	59-020-041	1x	59-020-049	115mm	3mm

INSTRUMENT CARE

Do not dismantle any part of the optical system.

Clean the magnification lenses only with soft clean dry paper.

Do not try to turn the viewing head through 180 deg. as the optical system will not work in this position.