

# DATA - SHEET 1035

No. 1035

Page. 1 of 3

Date. 22 / 11 / 2005

3D - TESTER

Order Code: 55-650-010

- Universal application - measures length, height, diameter & centre position
- Accuracy 0.008mm
- Minimum graduation: 0.01mm
- Clamping shank 3/4" (19.05mm) diameter
- Built in shock protection
- Compact solid metal housing provides protection against oil, dust and water and protects against sudden impacts.

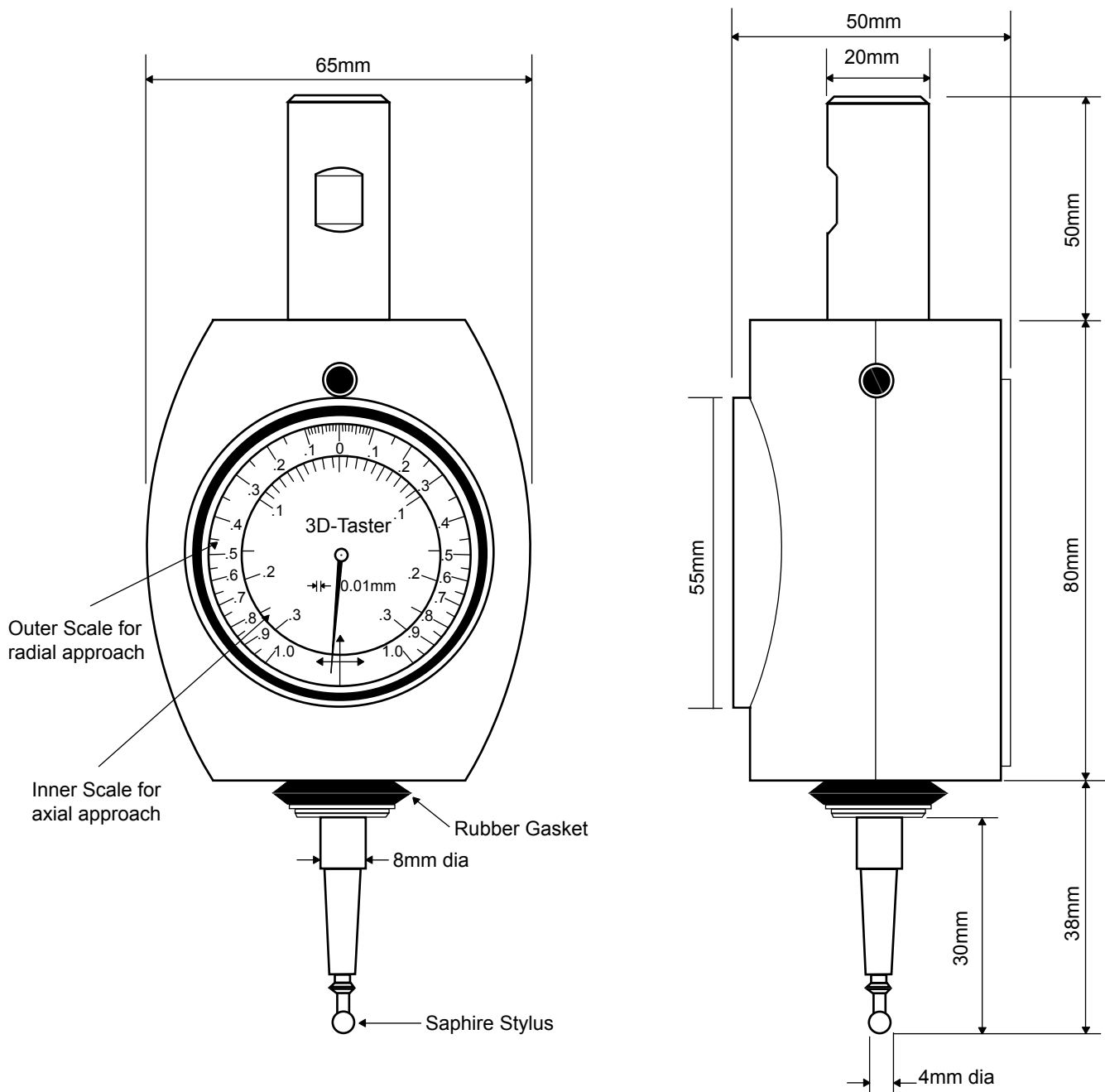

## Setting Instructions

The Tester Probe must be set concentric to the Machine Spindle as follows.

- 1 Mount the 3-D Tester to machine spindle by its 20mm mounting shank.
- 2 Fit a Plunger Dial Indicator fitted with a flat anvil to a Magnetic Base.
- 3 Fix Magnetic Base with Dial Indicator to Machine Work Table.
- 4 See Fig 1 for setting method
- 5 Position Dial Indicator flat probe against Ball stylus on 3-D Tester
- 6 Move Work Table so that Dial Indicator has 1 rev on rev counter and large hand is on zero.
- 7 Revolve 3-D Tester 180°
- 8 Note Dial Indicator hand position K1 (example 20)
- 9 Use adjusting screw "A" on 3-D Tester to move 3-D Tester Probe to K2 position
- 10  $K2 = K1$  divided by 2 (example  $20/2 = 10$ )

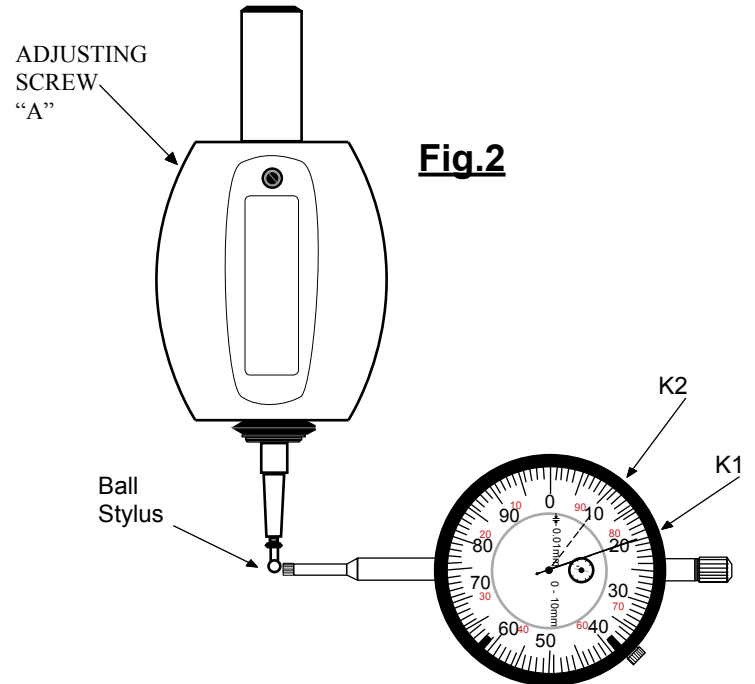
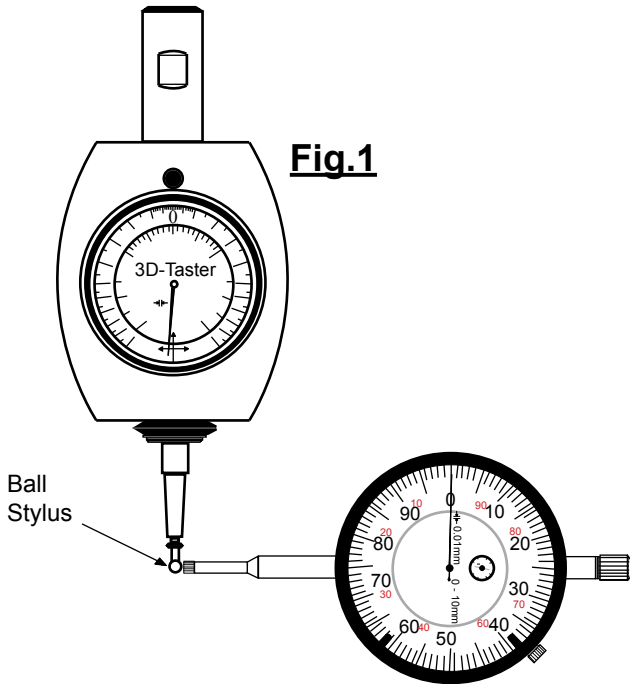

- 11 Revolve 3-D Tester 90°
- 12 Position Dial Indicator flat probe against Ball stylus on 3-D Tester
- 13 Move Work Table so that Dial Indicator has 1 rev on rev counter and large hand is on zero

- 14 Revolve 3-D Tester 180°
- 15 Note Dial Indicator hand position K1 (example 18)
- 16 Use adjusting screw "B" on 3-D Tester to move 3-D Tester Probe to K2 position
- 17  $K2 = K1$  divided by 2 (example  $18/2 = 9$ )
- 18 Revolve 3-D Tester 360°. Note Dial Indicator hand remains still
- 19 If there is any movement in Dial Indicator Hand, repeat from 1-18

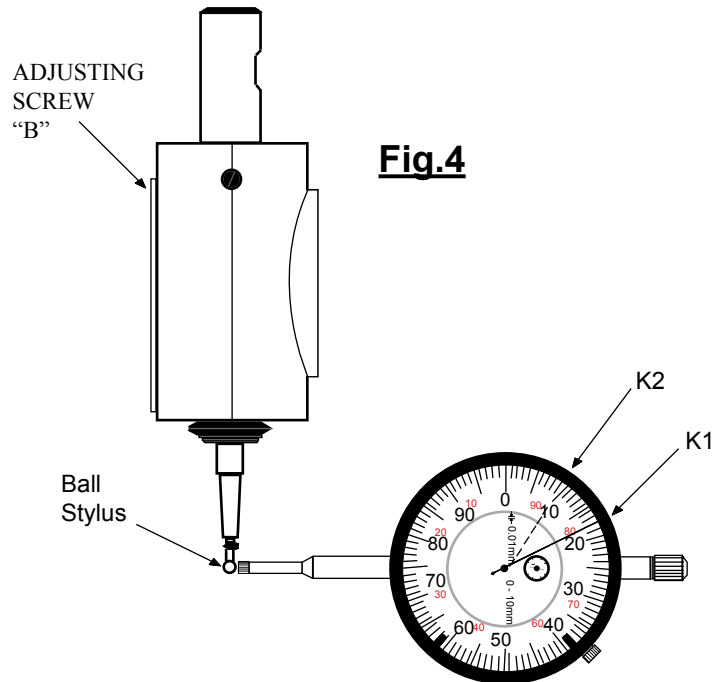
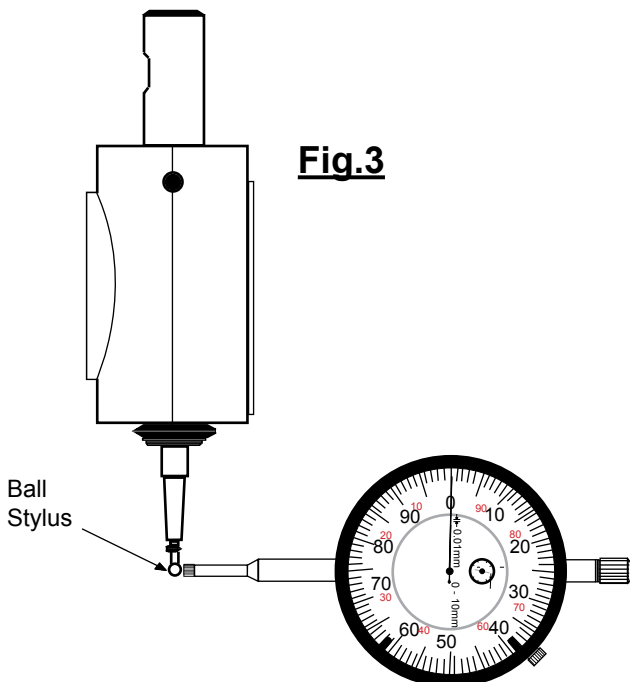

## Locating Centre of Round or Rectangular Components

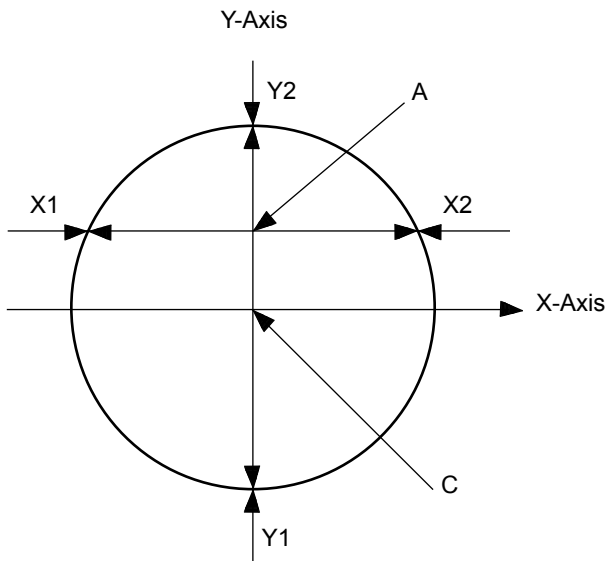

DIAGRAM 1  
Round Hole or Spigot

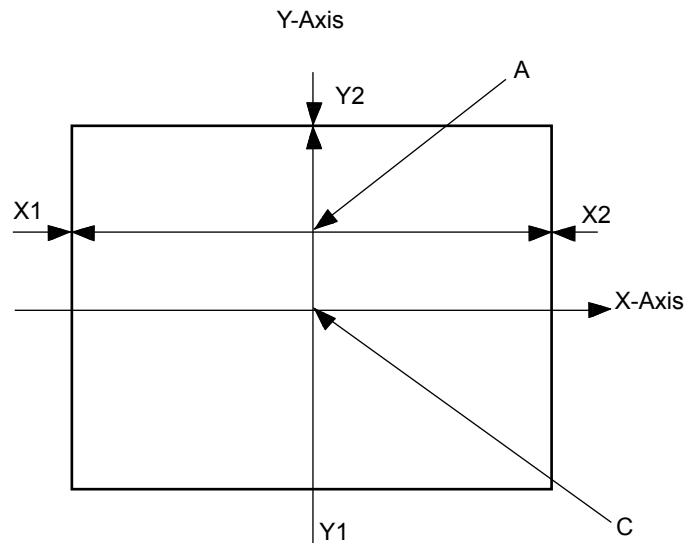
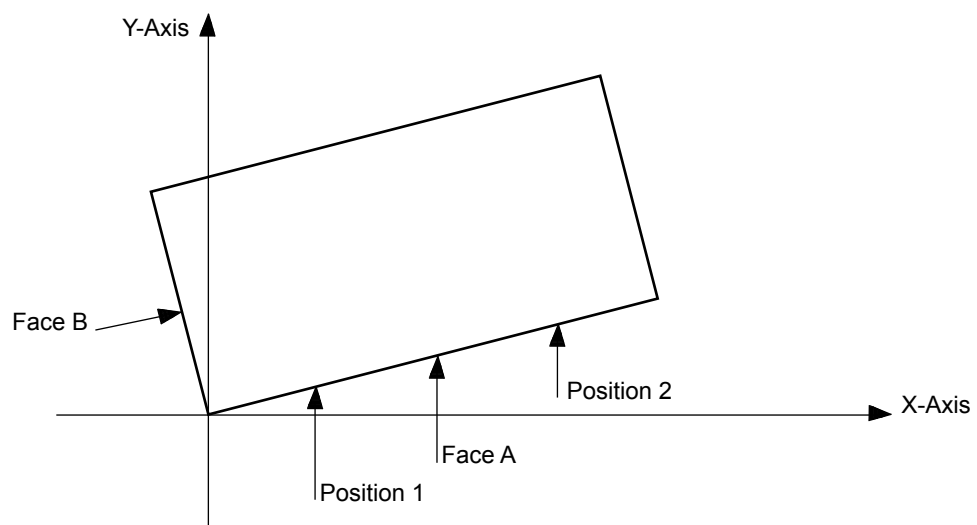

DIAGRAM 2  
Rectangular Hole or Spigot

- 1 Position component along X-Axis to contact Ball Stylus, so that indicator hand reads zero on 3-D Tester.  
Note X1 position on machine Readout
- 2 Re-position component along X-Axis to contact Ball Stylus so that Indicator Hand reads zero on 3-D Tester.  
Note X2 position on Machine Readout.
- 3 Move component along X-Axis to "A" position  
 $A = \frac{X2 - X1}{2}$
- 4 Component along Y-Axis to contact Ball Stylus so that the Indicator Hand reads zero on the 3D-Tester at Y1 position.  
Note reading on Machine Readout position.
- 5 Component along Y-Axis to contact Ball Stylus so that the Indicator Hand reads zero on the 3D-Tester at Y2 position.  
Note reading on Machine Readout
- 6 Move component to C position which is component centre  
 $C = \frac{Y2 - Y1}{2}$

### SET. Component Side Parallel To A Machine Axis (Example: set face "A" parallel to x-axis)



- 1 Move component to place Ball Stylus at position 1 on face A. Adjust Y-Axis to move Indicator hand to zero.  
Note X1 & Y1 readings on Machine Tool readout.
- 2 Move component to place Ball Stylus at position 2 on face A. Adjust Y-Axis to move Indicator hand to zero.  
Note X2 and Y2 reading on Machine Tool readout.
- 3 Adjust rotary worktable by the angle as calculated by  $\tan \alpha = \frac{(Y2 - Y1)}{(X2 - X1)}$

**Determin the co-ordinate value of the converging point  
of 2 intersecting sides of a square or rectangle**

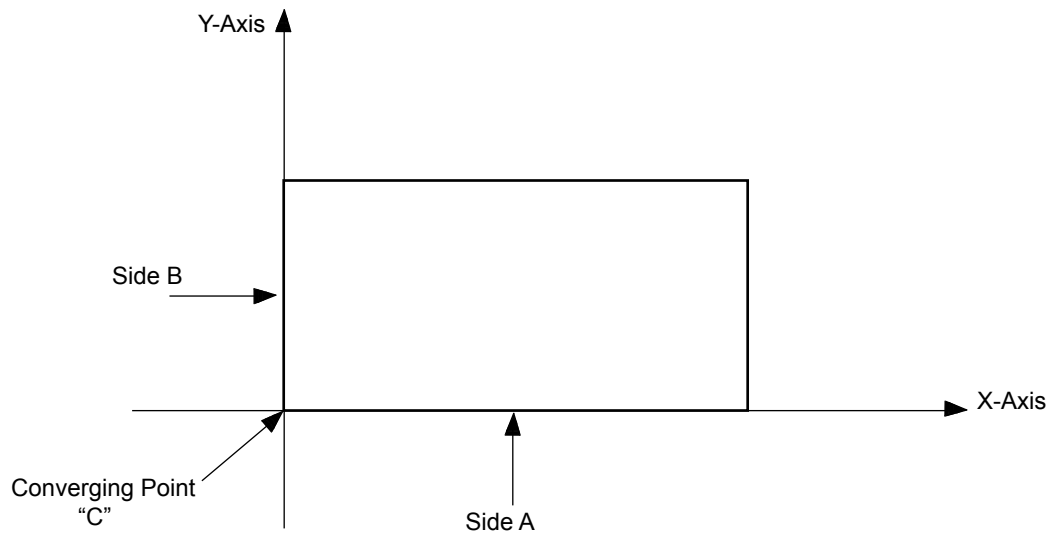

- 1 First set side "A" parallel to X-Axis as previously described
- 2 Move component to place Ball Stylus against face "A".  
Adjust Y-Axis to move Indicator Hand to zero.  
Note Machine Tool readout = XA
- 3 Repeat procedure for face "B"  
Note Machine Tool readout = YB
- 4 Co-ordinate values for Point C = XA & YB respectively.

**GENERAL MEASUREMENTS**

When the Ball Stylus is in contact with a component face and the dial hand reads zero.  
The component face and machine spindle centre are directly in line.

Measurements can be taken from this point using the machine readout.  
All measured positions must repeat the zero position of the dial hand.