

Electrical Splash Proof Micrometer

Linear Code: 50-295-025

Specification

- Splash proof design to IP54
- Digit resolution: 0.001mm / Barrel resolution: 0.01mm
- 3 button function: power, ABS/INC, set
- Ratchet thimble
- Ball anvil attachment included
- Tungsten carbide measuring faces

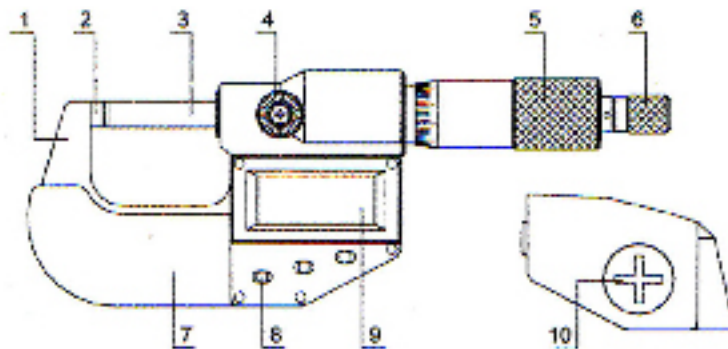

- 1. Frame
- 2. Anvil
- 3. Spindle
- 4. Locking Device
- 5. Scale reading device
- 6. Ratchet Stop
- 7. Frame cover
- 8. Three keys
- 9. LCD display
- 10. Battery cap

Front View

Part of back view

1. LCD Display

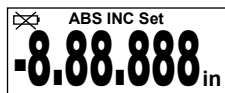

in : Inch measuring mode
 INC: Relative measuring mode
 ABS: Absolute measuring mode

: Battery voltage is low
 Set: Origin set

2. Operation

2.1 ON/OFF: Power on/off

2.2 SET: Setting origin data for absolute measurement: "Set" sign displayed on LCD.

Origin of metric is 0, 25, 50 --- 275mm.

Origin of inch is 0, 1", 2" --- 11"

Setting origin data automatically after reset battery.

Default origin data of micrometer head is 0.

2.3 ABS/INC: Absolute and relative measuring mode conversion: "INC" sign displayed on LCD in relative measuring mode, otherwise absolute measuring mode.

Electrical Splash Proof Micrometer**3. Power**

- Use a SR44 battery. Replace the battery when display data is blurring.
- If not used in about five minutes, the power will auto-off. The micrometer will wake up when pressing "ON/OFF" key or turning the spindle. Power off the micrometer by pressing "ON/OFF" key to save battery if not used.
- Remove the battery cap by turning it counterclockwise with a coin.
- Put a new battery with the positive (+) side up. Secure the battery cap by turning it clockwise.

4. Precautions

- Do not subject the instrument to blows or knocks. Do not drop it apply excessive force to it. Do not disassemble the instrument. The spindle is designed so that it cannot be removed from the inner sleeve. Do not move it past the upper limit of the measuring range.
- Do not press the key with a pointed object. Pressing the key along its moving direction, otherwise it will affects the key's sensitivity.
- Do not use or store the instrument under direct sunlight, or in an excessively hot or cold place.
- Do not let the instrument near strong magnetic field and high voltage.
- Use a soft or a cotton swab that is dry to wipe stains from the instrument. Do not use organic solvent such as acetone and benzene.
- Wipe measuring faces of the instrument before use it.
- Remove the battery if the instrument not used for a long period of time.

5. Specifications

Measuring force: 5 - 10N

Power consumption: $\leq 35\mu A$

Operating temperature: 0 - 40°C

Storage temperature: -20 - 60°C

6. Trouble Shooting

| Failure | Causes | Repairing |
|--|---|--|
| Display "E 1" on LCD | Data overflow | Move spindle reverse or press "ON/OFF" key. |
| Display "E 3" on LCD | 1. Sensor overflow. 2. Something wrong with sensor. | 1. Reset battery. 2. Return the micrometer for repair. |
| Measuring data is not correct | 1. Dirty measuring surfaces. 2. Preset data isn't correct. | 1. Clean measuring surfaces. 2. Inspect preset data and reset it. |
| No display on LCD | 1. Battery is not properly set. 2. Battery doesn't work. | 1. Reset battery. 2. Replace battery. |
| 1. Display isn't steady. 2. Display is confusing. 3. Display remains dead. | 1. Battery voltage under 1.45v. 2. Battery voltage under 1.45v. 3. Battery is not properly set. | 1. Replace battery. 2. Replace battery. 3. Reset battery. |
| Display blurring | Battery voltage under 1.45v. | Replace battery. |